

## FOOT REMOTE CONTROL WITH 2 SHIFTERS IN GREY

TO OPERATE THE ELECTRICAL HEIGHT ADJUSTMENT OF THE PYLON COLUMN



### PRODUCT

All electrically height-adjustable and tiltable display mounts are supplied with a cable control panel. This footswitch extends this functionality. The switch is equipped with 2 buttons and controls the electrical height adjustment of the display mount. The column can be driven up and down.

The operability by foot switch can not be retrofitted!

### FEATURES

- Simple and quick control by foot
- Colour: grey



Display mount

Item number	REM-FOOT	
Width / Height / Depth	195 mm / 37 mm / 135 mm	7.7" / 1.4" / 5.3"
Weight	0,7 kg	1.5 lbs

DIMENSIONS

in mm / inch

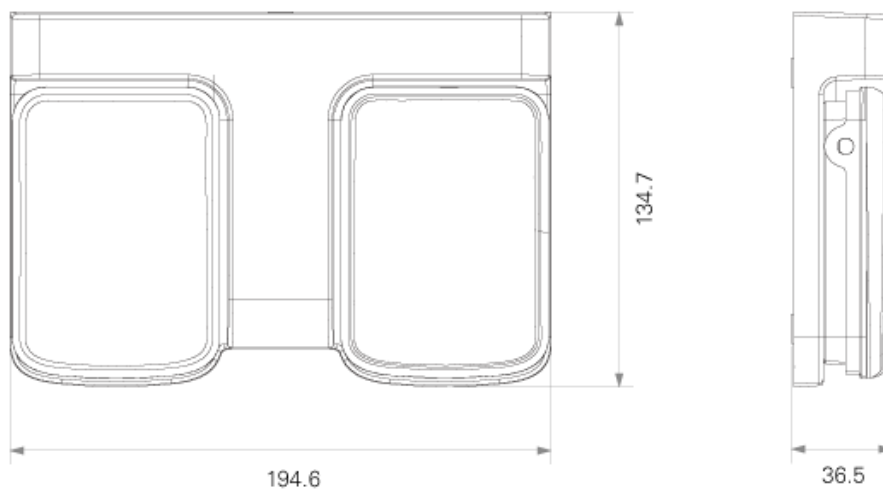

MANUFACTURER:

CONEN Produkte GmbH  
 Conenstr. 4  
 54497 Morbach-Gonzerath

Phone: +49 (0) 6533 75-100  
 Fax: +49 (0) 6533 75-600  
 E-Mail: [info@conenmounts.com](mailto:info@conenmounts.com)

Germany

[www.conenmounts.com](http://www.conenmounts.com)