

MOTORIZED MOBILE HEIGHT AND TILT ADJUSTABLE MONITOR STAND, 50 CM OF VERTICAL TRAVEL

COLUMN BLACK ANODIZED, ANTI-COLLISION, C-STYLE BASE



PRODUCT

Motorized height adjustable & tilt adjustable mobile monitor stand for 43" touch screen monitors.

Our mini tilting device is mobile, height adjustable and tiltable. The system was designed for use in kindergartens. The mobile monitor stand offers a 10" smooth height adjustment and 0-90° tilt adjustment - both settings are electrical. The mobile holder allows the use of any touchscreen monitor with a screen diagonal of 43" in board mode or as a table system or in any position in between. The system can be adjusted in height and incline at the same time or one after the other and stopped in any position a simple movement of the system between different rooms and makes the TV trolley once again the ideal solution for work environments in which a high degree of flexibility is required.

The TV trolley comes completely pre-assembled in one packaging unit and can be sent by parcel service.

FEATURES

- Mobile monitor stand with motorized height and tilt adjustment
- Compatible with 43" touch screen monitors
- 20" of smooth motorized height adjustment, actuator 2000N, 47 mm/ 1.85" per second
- Tilt feature to position the display in any tilted position between 0 and 90 degrees
- Wired remote is standard included
- collision function



Display mount



Mobile



Table system



Motorized height adjustable



Single display



5 years warranty



Max. load
136 kg / 299.8 lbs



Max. Vesa
400 x 400

Item number	SCETTACM25BK	
Vesa horizontal / Vesa vertical	400 mm - 400 mm / 400 mm - 400 mm	
Frame for all	43"	
Load capacity	136 kg	299.8 lbs
Width / Height / Depth	757 mm / 660 mm - 1160 mm / 506 mm	29.8" / 26" - 45.7" / 19.9"
Weight	35,1 kg	77.3 lbs
Warranty	5 years limited warranty	
Frame color	RAL 9005 deep black	
Column color	Black anodized	
Base color	RAL 9005 deep black	
Packages	Package dimensions WxHxD	Package weight
SCETTACM25BK	782 x 602 x 548 mm / 30.8 x 23.7 x 21.6"	40 kg / 88.2 lbs

DIMENSIONS

in mm / inch

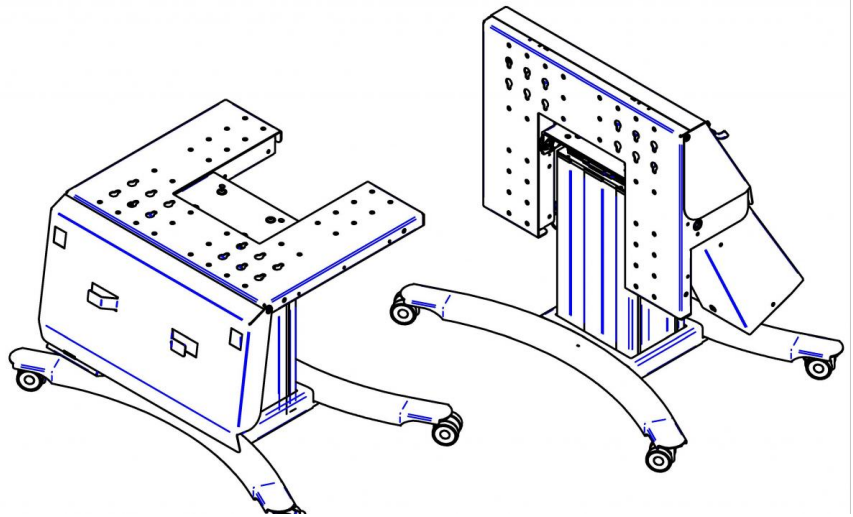
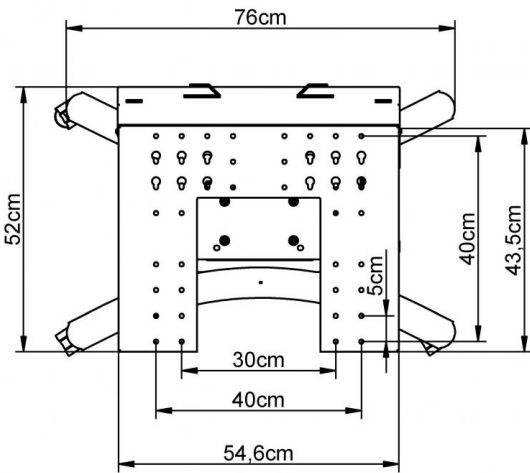
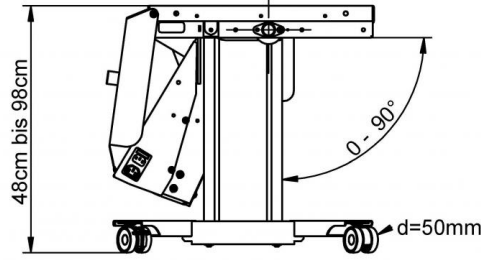
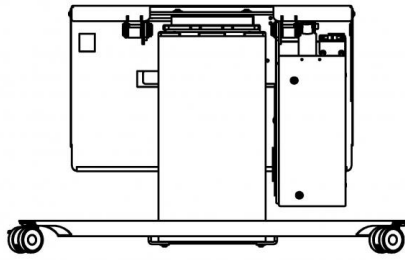

MANUFACTURER:

CONEN Produkte GmbH
 Conenstr. 4
 54497 Morbach-Gonzerath

Phone: +49 (0) 6533 75-100
 Fax: +49 (0) 6533 75-600
 E-Mail: info@conenmounts.com

Germany

www.conenmounts.com