

ELECTRICALLY HEIGHT-ADJUSTABLE MOBILE MONITOR STAND FOR INTERACTIVE DISPLAYS

VESA 200X200 TO 800X600 FOR DISPLAYS UP TO 86" (MAX. 120 KG)

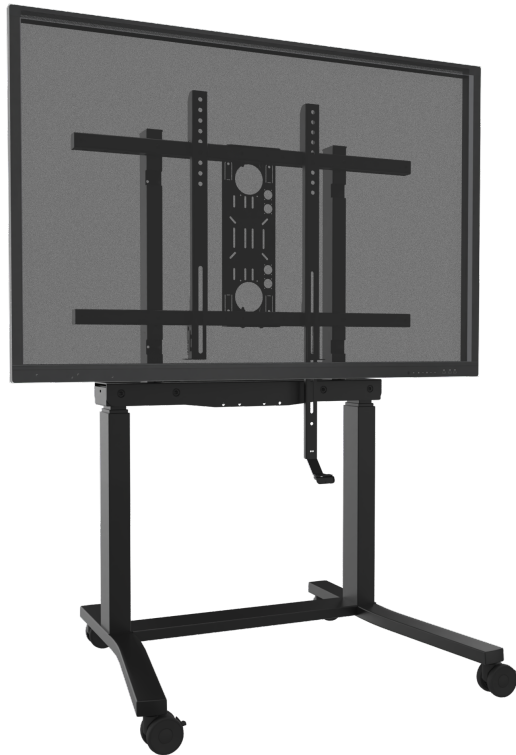

PRODUCT

Model "DCS" - Electrically height-adjustable mobile stand for interactive displays.

The mobile electric lift system is designed for displays with a size of up to 86" and a load capacity of max. 120 kg. The height is infinitely adjustable using a hand switch. The two double telescopic pylon columns, which have a lifting range of 650 mm, make the system extremely versatile.

The integrated anti-collision feature increases safety to prevent injury to the user or damage to the system. If contact with an obstacle occurs, the system automatically reverses in the opposite direction.

The 75 mm lockable castors allow the system to be used on a wide variety of floor coverings, such as stone floors, PVC flooring or deep-pile carpets, while guaranteeing the necessary stability. The V-shaped frame ensures optimum accessibility to the display.

The system comes with a mounting plate as standard to accommodate a mini PC (VESA 75 and VESA 100) and a power strip. The option of connecting additional accessories such as a camera and keyboard shelf, as well as whiteboard side wings, help to increase user-friendliness and improve the range of applications in the training sector.

The product is supplied disassembled in a cardboard box.

FEATURES

- > VESA mount up to max. VESA 800 x 600
- > Travel speed: 70mm/sec.
- > Stroke: 65 cm
- > Load capacity: 120 kg
- > incl. anti-collision protection
- > Center of display approx. 1,080- 1,730 mm
- > Mounting plate incl. VESA 75/100 for mounting a mini PC, power strip etc.
- > Quick and easy display mounting thanks to suspension rails with quick-release fastener
- > Rolling frame with 75 mm castors
- > CE certified



Display mount



Mobile



Motorized height adjustable



Single display



5 years warranty

Max. load
120 kg / 264.6 lbsMax. Vesa
800 x 600

Item number	DCS-M65	
Vesa horizontal / Vesa vertical	200 mm - 800 mm / 200 mm - 600 mm	
Frame for all	86" max.	
Center to floor distance	1080 mm - 1730 mm	42.5" - 68.1"
Load capacity	120 kg	264.6 lbs
Width / Height / Depth	900 mm / 1400 mm - 2050 mm / 740 mm	35.4" / 55.1" - 80.7" / 29.1"
Weight	40 kg	88.2 lbs
Warranty	5 years limited warranty	
Frame color	RAL 9005 deep black	

DIMENSIONS

in mm / inch

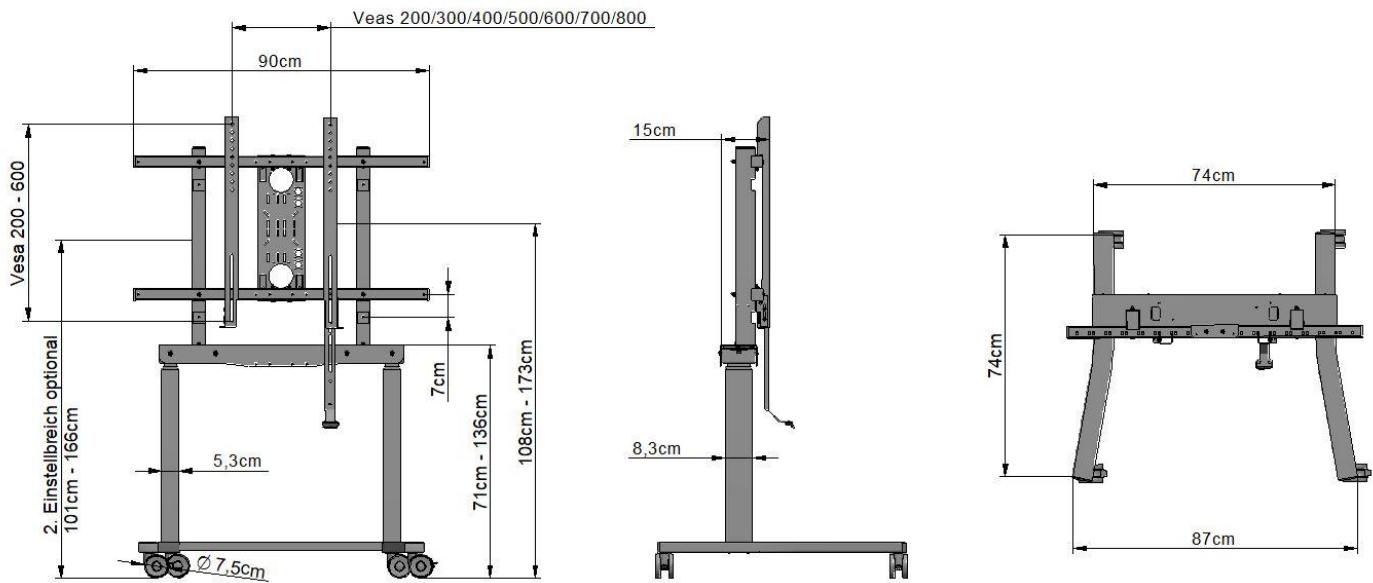

MANUFACTURER:

CONEN Produkte GmbH
 Conenstr. 4
 54497 Morbach-Gonzerath

Phone: +49 (0) 6533 75-100
 Fax: +49 (0) 6533 75-600
 E-Mail: info@conenmounts.com

Germany

www.conenmounts.com