

## ELECTRICALLY HEIGHT-ADJUSTABLE MONITOR STAND FOR INTERACTIVE DISPLAYS

VESA 200X200 TO 800X600 FOR DISPLAYS UP TO 86" (MAX. 120 KG)

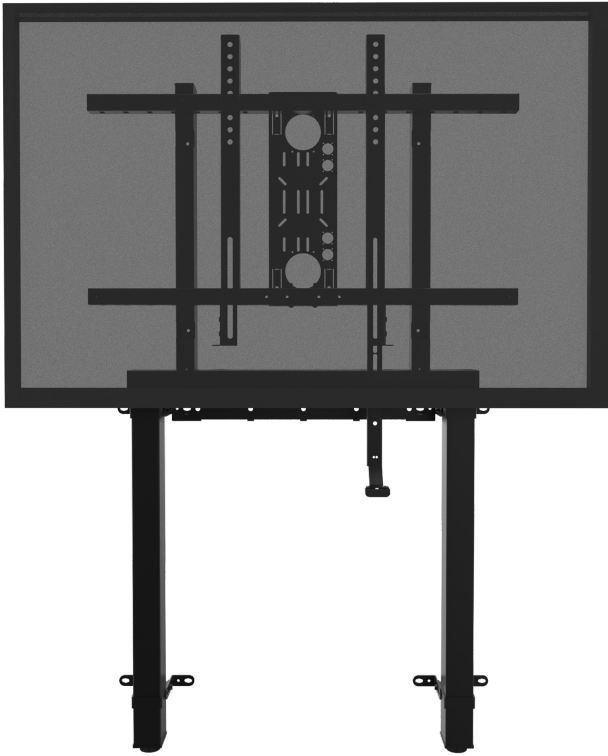

### PRODUCT

Model "DCS" - Electrically height-adjustable stand for interactive displays, for floor/wall mounting.

The electric lift system is designed for displays with a size of up to 86" and a load capacity of max. 120 kg. The height is infinitely adjustable using a hand switch. The two double telescopic pylon columns, which have a stroke of 1,000 mm, make the system extremely versatile.

The integrated anti-collision feature increases safety to prevent injury to the user or damage to the system. If contact with an obstacle occurs, the system automatically reverses in the opposite direction.

The system is designed for floor-wall mounting so that it can also be installed on lightweight walls. The wall mounting brackets are included in the scope of delivery.

The system comes with a mounting plate as standard to accommodate a mini PC (VESA 75 and VESA 100) and a power strip. The option of connecting additional accessories such as a camera and keyboard shelf, as well as whiteboard side panels, help to increase user-friendliness and improve the range of applications in the training area.

The product is supplied disassembled in a cardboard box.

### FEATURES

- VESA mount up to max. VESA 800 x 600
- Travel speed: 70 mm/sec.
- Stroke: 100 cm
- Load capacity: 120 kg
- incl. anti-collision protection
- Center of display approx. 1,200- 2,220 mm
- Mounting plate incl. VESA 75/100 for mounting a mini PC, power strip etc.
- Quick and easy display mounting thanks to suspension rails with quick-release fastener
- Floor/wall mounting



Display mount



Wall mounted



Motorized height adjustable



Single display



5 years warranty



Max. load  
120 kg / 264.6 lbs



Max. Vesa  
800 x 600

Item number	DCS-W100	
Vesa horizontal / Vesa vertical	200 mm - 800 mm / 200 mm - 600 mm	
Frame for all	86" max.	
Center to floor distance	1200 mm - 2200 mm	47.2" - 86.6"
Load capacity	120 kg	264.6 lbs
Width / Height / Depth	900 mm / 1520 mm - 2520 mm / 150 mm	35.4" / 59.8" - 99.2" / 5.9"
Weight	45 kg	99.2 lbs
Warranty	5 years limited warranty	

DIMENSIONS

in mm / inch

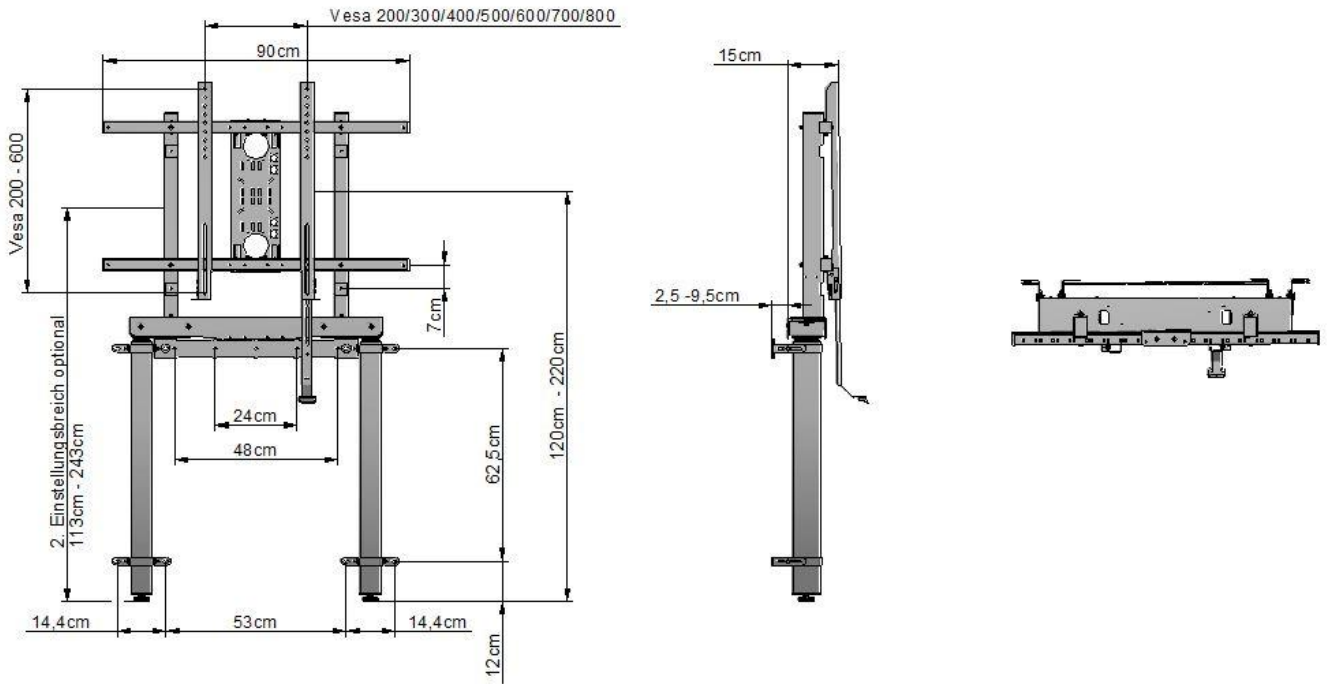

MANUFACTURER:

CONEN Produkte GmbH  
 Conenstr. 4  
 54497 Morbach-Gonzerath

Phone: +49 (0) 6533 75-100  
 Fax: +49 (0) 6533 75-600  
 E-Mail: info@conenmounts.com

Germany

[www.conenmounts.com](http://www.conenmounts.com)